



...connecting to the aftermarket

# Installation Manual Double DIN Kit

## CT23VW12L

### • VW Golf VII 2013->

Compatible with these Double-DIN devices:

### Double-DIN Navigation

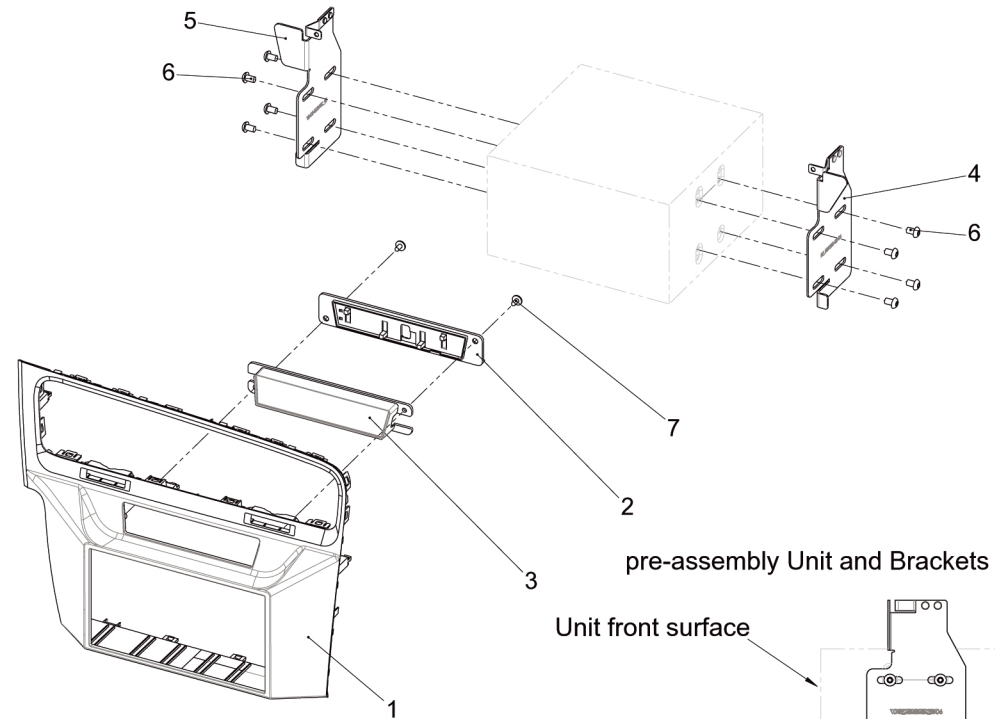

#### Double DIN Set contents

- (1) Facia Plate
- (2) Cover
- (3) Housing
- (4) Mounting Bracket Right
- (5) Mounting Bracket Left
- (6) Flat Headed Screw
- (7) Self Tapping Screw with Collar



Unclip and remove panel under OEM head unit



Unclip OEM head unit panel



Unclip air vents (special VW tool may be required)

Remove OEM head unit panel by pulling it toward your direction

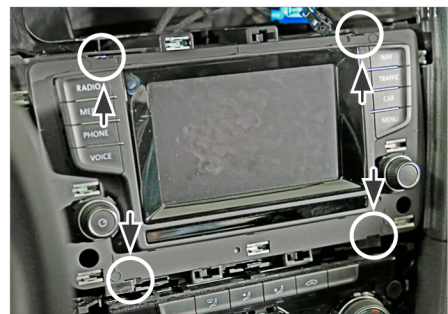

Insert radio release keys  
Remove OEM head unit



**Notes:**

**Notes:**

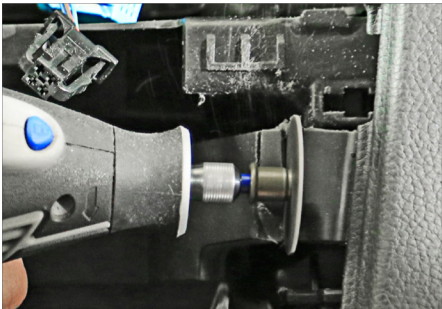

Several plastic parts must be cut and removed in order to clear space for 2-DIN head unit

Cut plastic (see arrows) and remove it

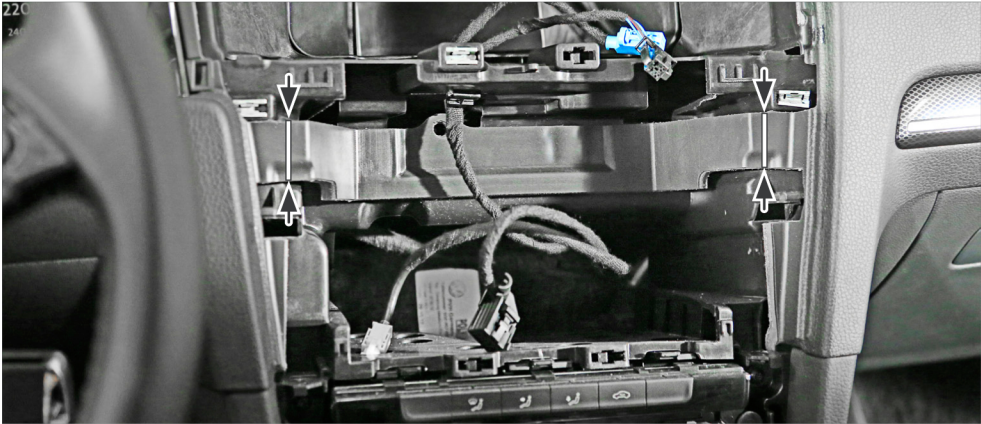

Cut plastic bridge underneath removed plastic (see arrows)

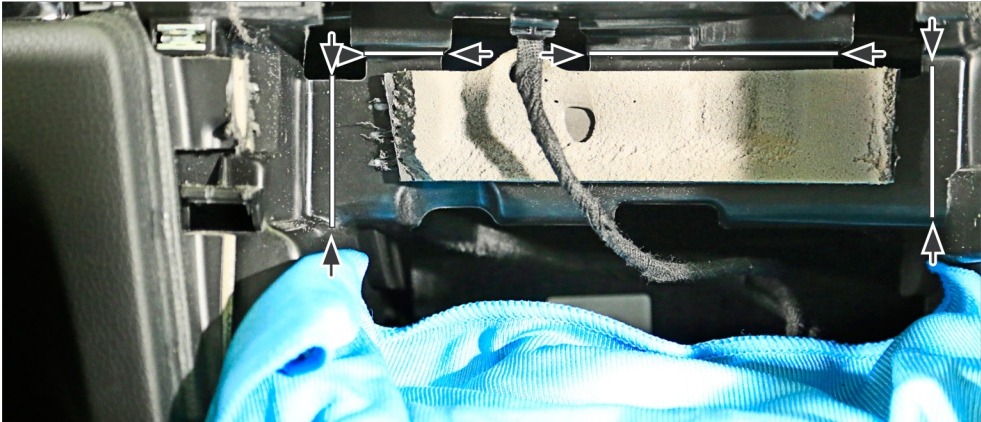



Dashboard after plastic has been cut away

Mount mounting brackets to double DIN head unit

### pre-assembly Unit and Brackets

Unit front surface

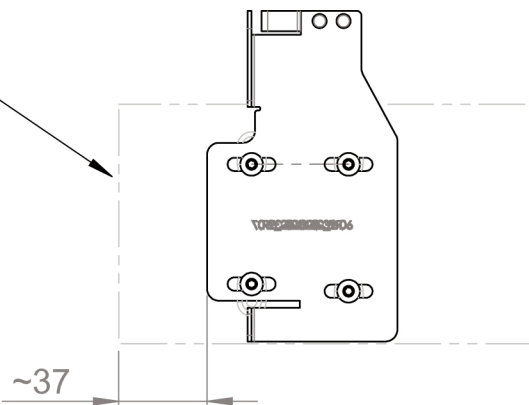
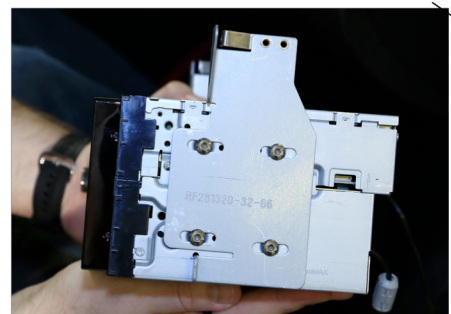

Remove air vent unit from OEM panel

Mount air vent unit to double DIN head unit

Connect all required circuit points. Mount double DIN head unit to dashboard. Place fascia plate. Reinstall everything in reverse order to finish installation

